

Elan Dryer  
02170 / 02174 / 02176 / 02422  
Edition 2-2019

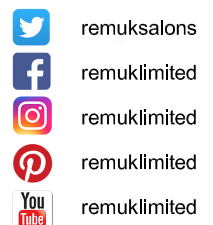

REM (UK) Limited  
Glenfield Mill,  
Glenfield Road,  
Nelson, Lancashire  
BB9 8AW  
T: +44 (0)1282 619 977  
F: +44 (0)1282 619 617  
E: sales@rem.co.uk  
W: www.rem.co.uk

Made in Britain 



**Product Name:** Elan Dryer

**Product Type:** Dryer

**Product Codes:**

- 02170 - Elan Couch Hood
- 02174 - Elan Mobile C/W Pole & base
- 02176 - Elan Wall Hood
- 02422 - Wall Arm - Elite

**Standard Equipment:**

- Manual control for heat intensity and time duration.
- Adjustable hood & arm for accurate positioning
- Height adjustable pole (mobile)

**Optional Equipment:**

- N/A

**Main Construction:**

- Polycarbonate construction with alloy and chrome reflectors
- Satin black polycarbonate

**Finish:**

- Wall arm: Steel with internal steel spring. Black only.
- Elite Hood: Polycarbonate with clear visor extension. Available in white (standard) or black (option).

**Features:**

- Quality, modern styled dryer
- Wall arm mounting
- Variable heat and time controls
- Integral visor
- Large drying chamber



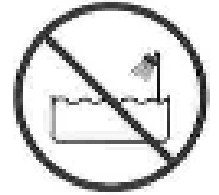

## **Installation**

The dryer should be examined for damage on receipt. All damages should be reported to REM within 72 hours of delivery. It is important that the voltage on the rating plate matches that of your supply. If in doubt, contact your Approved Service Engineer or REM direct. Your dryer is fitted with a 3 pin plug (except wall models) and it should be noted that any replacement should be rated with a 13-amp fuse only.

The maximum loading of this dryer is 1000W. Installation of a RCD or Residual Current Device is advisable (please seek expert electrical advice on this matter).

## **GENERAL WARNINGS**

- *Do not remove the top cover of this dryer without first disconnecting the mains power supply.*
- *Do not cover the top of the dryer (with a towel for example). Leave the top of the dryer free so that air can circulate through the grill. Without proper air intake the dryer will not work properly.*
- *Always ensure that your client wears a suitable hair net during the drying process.*
- *Take care when assembling and installing the unit on a spring loaded pole. Please read the pole and base assembly instructions carefully to avoid accidents. Once the dryer hood is in place on the pole it will have the effect of floating. It can now be set at the desired height and secured by tightening the wing nut on the pole.*
- *See separate instructions for the fitting of the wall arm.*
- *Never loosen the pole wing nut if the dryer has been removed from the pole.*
- *In the case of a wall hood model please keep safe the transit lock provided with the wall arm. If the dryer needs to be removed from the wall arm, the transit lock should be fitted to prevent the wall arm springing upwards.*
- *The dryer can be cleaned using a cloth moistened with water or ordinarily commercially available detergents, provided they do not contain alcohol or acetone. However, before cleaning make sure that the appliance is disconnected from the electrical power supply and that it has cooled down properly.*
- *Any repairs or maintenance should be carried out by suitable Service Engineers.*
- *Never use this dryer near water contained in bath tubs, sinks, or other vessels. This dryer must not be used in a bathroom. Water poses a serious hazard even when the device is switched off; do not leave the device connected to the power supply after use near water.*
- *This dryer is not to be used by children or persons with reduced physical, sensory, or mental capabilities, or lack of experience and knowledge, unless they have been given supervision or instruction.*
- *Children must not play with the dryer.*

## **ELAN NEXT GENERATION**

**Programming the Time** - Set the time from 0 to 60 minutes by turning the knob of the timer clockwise. When the time has elapsed, the knob goes back to the '0' position automatically. During operation of the dryer it is always possible to turn the knob to the '0' position, thus using the knob as a mains switch.

**Programming the Temperature** - Set the desired temperature by turning the knob of the thermostat clockwise. The orange warning light lit up indicates that the heating phase is in progress. The warning light turns off when the set temperature has been reached.

Elan Dryer - Mobile  
02174  
Edition 2-2019

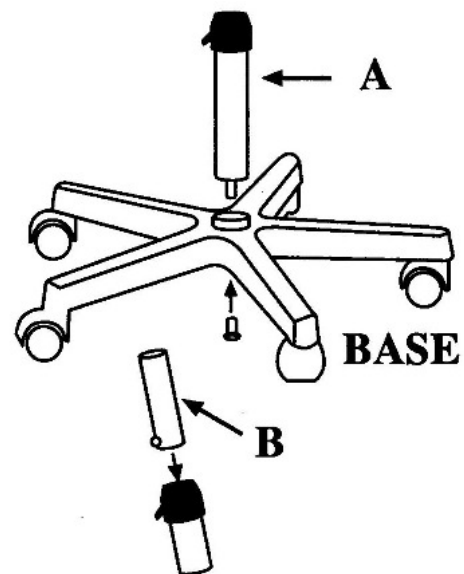

**WARNING – Please read these instructions thoroughly before attempting assembly.**

### **INSTRUCTION FOR USE OF SPRING COLUMN (2 PIECE DRYER POLE)**

1. Fix Spring Column 'A' (Lower Pole) to Base, using Setscrew & Washer supplied. (N.B. please ensure setscrew is tightened sufficiently to avoid any rattling noises being transferred through the pole when the Dryer is in use.)
2. Check wing nut is loose on Spring Column 'A'.
3. Place tube 'B' into Spring Column 'A' (notched end downwards enabling notch to fit via special groove in plastic moulding on Lower pole). Assert only enough pressure to ensure that notch has gone below moulding, allowing partial turn of the Upper Pole in either direction, to lock in place. Release pressure leaving both tubes fixed together.
4. **DO NOT DEPRESS TUBE 'B' AGAINST SPRING LOADING AT THIS STAGE.**
5. Place Hair Dryer or other appliance on tube 'B', the weight of which will automatically depress tube to a counter-balance (or 'floating') situation.
6. Tighten Wing-Nut on Lower Pole when appliance has been set at correct height.

**DO NOT UNSCREW THE WING NUT IF THE DRYER OR OTHER APPLIANCE IS NOT ON THE POLE ASSEMBLY. IF DISMANTLING, ENSURE WING NUT IS TIGHT BEFORE REMOVING APPLIANCE FROM POLE. USE ONE HAND TO BLOCK UPWARD MOVEMENT OF UPPER TUBE WHILST SLOWLY RELEASING WING-NUT. ALLOW SPRING MOVEMENT TO UNLOAD UPPER TUBE GRADUALLY UNTIL PRESSURE CEASES. RELEASE UPPER TUBE BY TURNING UNTIL NOTCH LINES UP WITH GROOVE IN PLASTIC MOULDING AND CAN BE LIFTED CLEAR.**

**WARNING!! ENSURE FACE AND OTHER PARTS OF BODY ARE WELL CLEAR WHEN CARRYING OUT THE ABOVE.**

**N.B. The spring mechanism can cause damage or injury if not used with care. No liability can be accepted in respect of any incident arising out of mis-use or incorrect handling.**

Elan Processor - Wall Arm  
02422  
Edition 2-2019

## WALL ARM FITTING INSTRUCTIONS

### IMPORTANT WARNINGS

DO NOT TURN ON POWER TO THE WALL ARM UNTIL DRYER HOOD IS CONNECTED.

DO NOT PUT FINGERS INSIDE THE PIVOT HOOD

This unit is permanently under spring tension and should be handled with extreme care during unpacking and fitting. Please refer to these notes before removing from box and attempting to fix. During transit the arm is locked in a horizontal position via the Transit Lock located at the main swivel joint. UNDER NO CIRCUMSTANCES SHOULD THIS BE REMOVED UNTIL THE ARM IS IN POSITION ON THE WALL PLATE AND THE DRYER OR PROCESSOR IS ALSO ATTACHED TO THE ARM. N.B. Best results will be obtained by having the installation carried out by a competent Electrical Contractor.

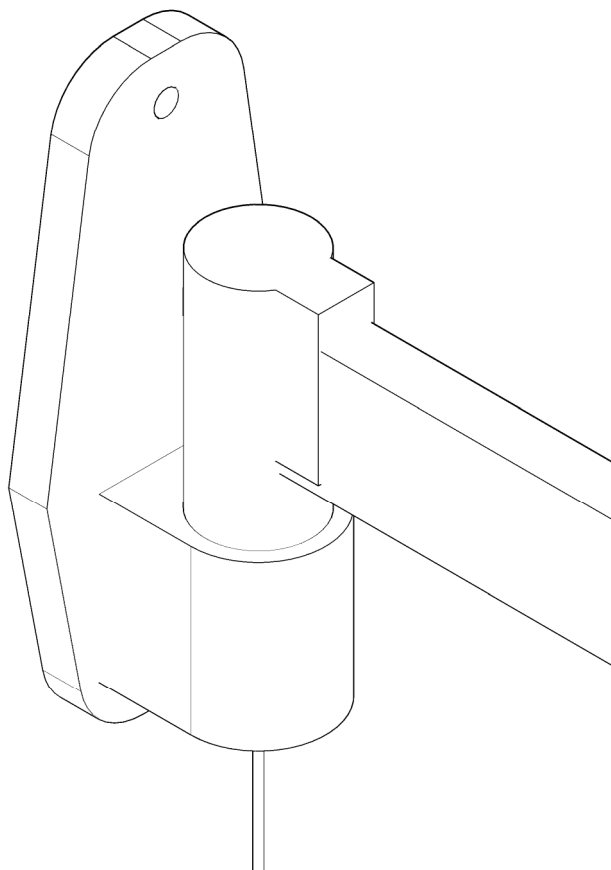
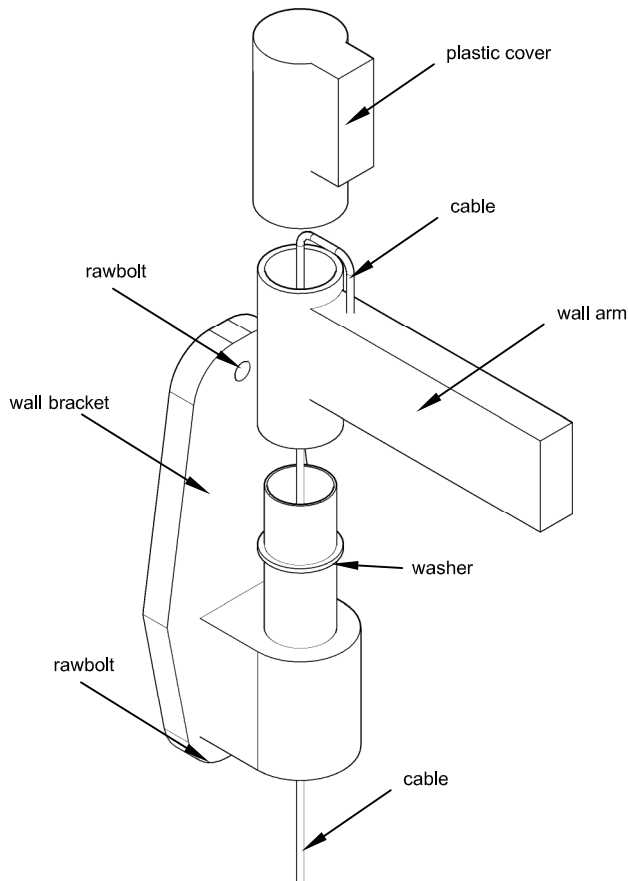

### 1. FITTING THE WALL PLATE OR BRACKET

The strength and/or substance of the wall or other structure upon which the unit is to be mounted, must be sufficient to support the weight of the arm and attached dryer or processor. (N.B. This must also allow for use of the arm at its maximum length.) Please consult a building contractor, or similar, if in doubt on this issue. The manufacturer will not accept responsibility for any accidents or failures in use, due to incorrect or poor installation. Having established suitability of the supporting structure, determine placement of the Wall-Plate (allowing a distance of 1.95 metres from the floor to the centre of the lower bolt-hole) and mark fixing points through both holes. Drill to suit M10 Rawbolts supplied (or similar fixings appropriate for supporting medium) and fit plate accordingly. Place Washer provided over the tube of the Wall Plate. Similarly, fit Wall Arm on plate ensuring it sits firmly on the washer.

Finally, thread cable through Wall Plate tube for connection to electrical supply source and slide plastic cover over and down onto Wall Arm to enclose cable and joint.

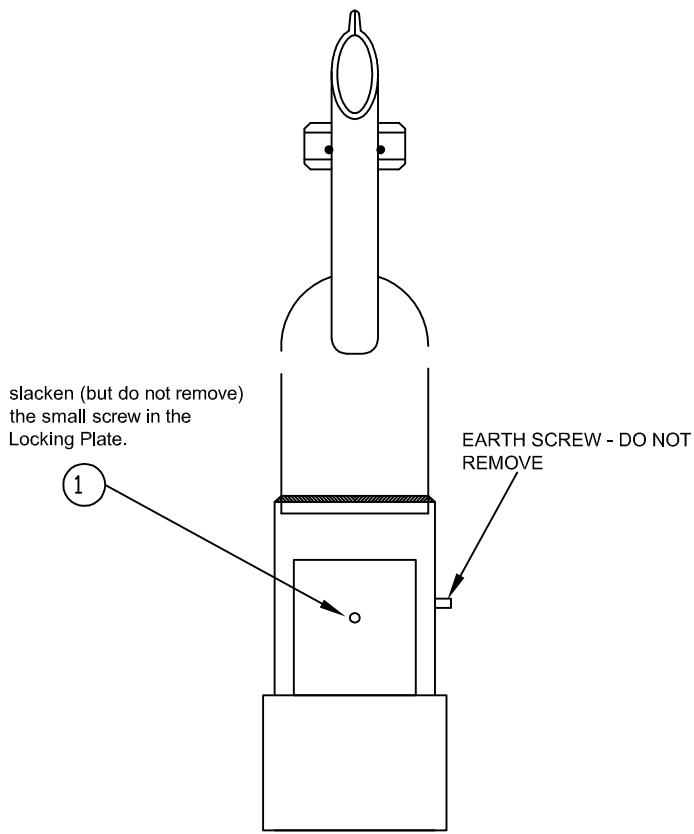

1. ATTACHING THE DRYER OR PROCESSOR

Using a flat-head screwdriver, slacken (but do not remove) the small screw in the Locking Plate [1].

Caution. On no account should the 'Earth Screw' (which is similar to the above) be tampered with, or removed, at any time. To do so, could affect the electrical safety of the arm. If in doubt, consult a qualified Electrical Contractor.

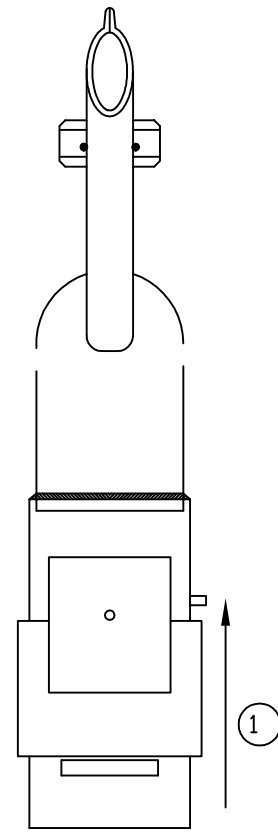

2. Lift Locking Collar [1].

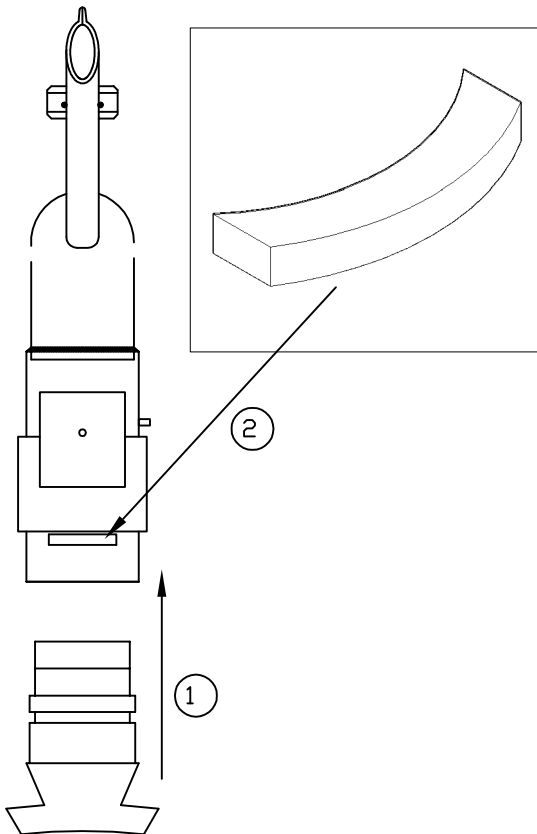

3. Insert Swivel Boss of Dryer or Processor into Pivot Hood [1], lining up the groove in the Boss with the slot in the Hood and place the Locking Wedge in position [2].

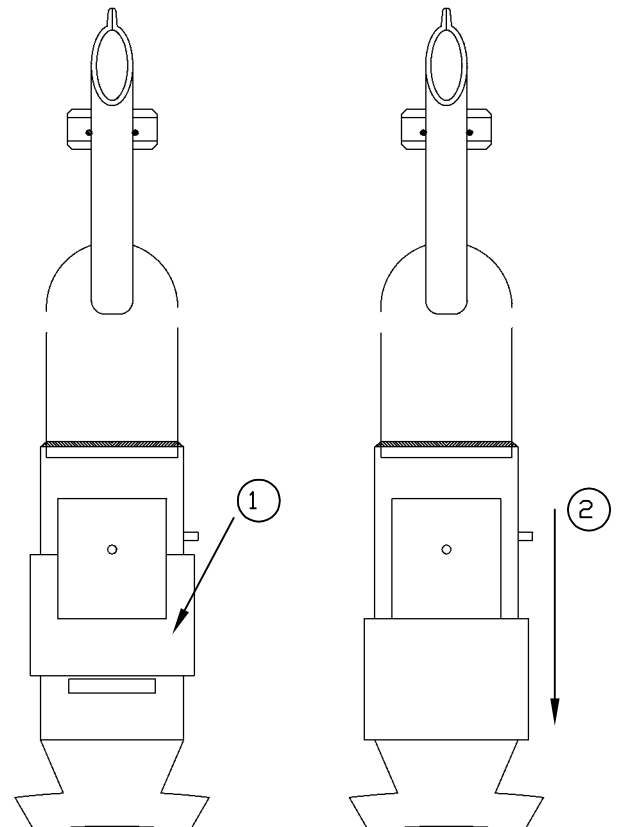

4. Let go of Locking Collar [1] allowing it to fall into place over the Locking Wedge [2].

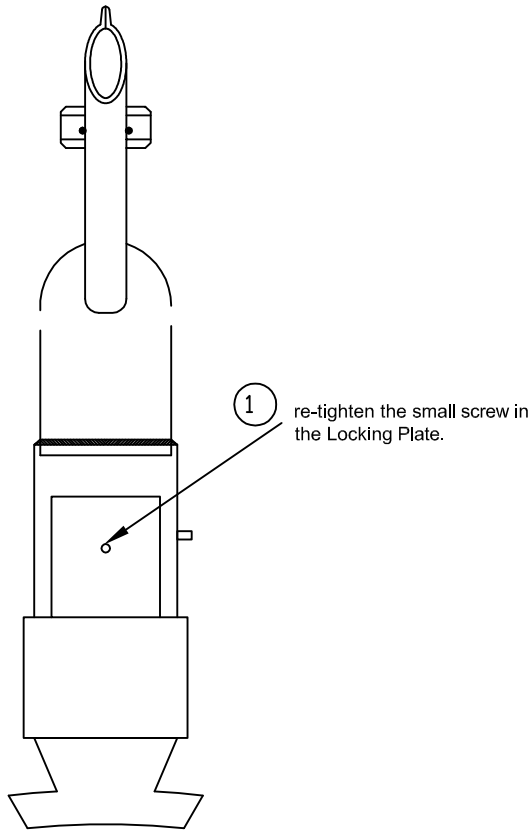

5. Rotate Dryer or Processor to check that it turns smoothly through 360 degrees before re-tightening screw in Locking Plate [1]. The Locking Wedge is now held securely, preventing the Dryer or Processor from dropping out of the Pivot Hood.

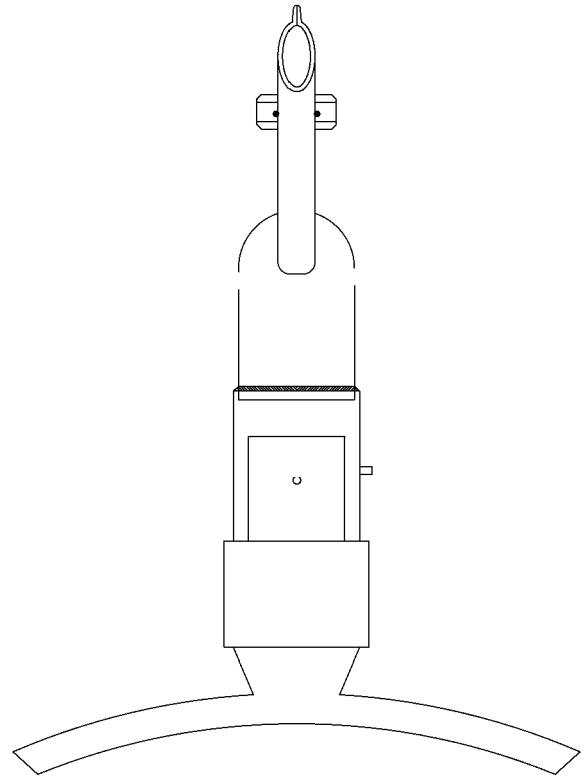
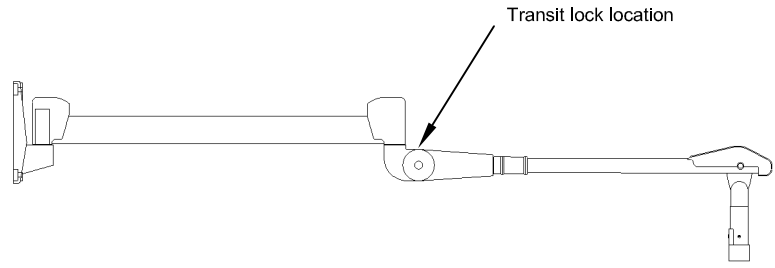

6. Once the Dryer or Processor is in position it is safe to remove the Transit Lock. To accomplish this, gently pull down the Lower Arm (front section) until there is no pressure on the Transit Lock, thus enabling easy removal. (Always keep Transit Lock in a safe place for future use. NEVER REMOVE the Dryer or Processor from the Arm, without first TURNING OFF THE POWER and re-locating the Transit Lock.)

## **Fabrics:**

### **DECLARATION OF CONFORMITY OF CERTAIN FIRE RETARDANCY STANDARDS.**

BS 7176 is the British Standard which specifies the requirements for the resistance to ignition of upholstered furniture manufactured for seating or similar usage, but excluding use on domestic furniture or transport seating. Tests have been carried out on all REM products and fabrics in accordance to BS EN 1021-1: 2006 and BS EN 1021-2: 2006 which satisfy the performance requirements of Low Hazard Category of BS 7176 (resistance to ignition sources: Smouldering Cigarette and Match Flame Equivalent).

Typical examples of furniture that are required to meet the Low Hazard Category are Schools, Colleges, Offices, and Day Centres.

All of the cloths the REM swatch are available on the majority of REM products and meet the Medium Hazard Category (Public Buildings, Restaurants, Hotel Bedrooms, Hospitals etc) of BS 7176 which is similar to the above but also includes the Ignition Source 5 test of BS 5852: 2006.

It should be noted also, that whilst the test levels for the various hazard categories are set after careful consideration of the particular end-user environments involved, they are not intended to reflect the behaviour of the upholstery in a fully developed fire. A label is available for use on items produced in accordance with this standard, although there is no legal requirement to attach said label. These can be supplied on request at the time of ordering (printed to suit Low and Medium Hazard Only).

All products are subject to availability. REM reserves the right, without further notice, to alter the material specification of our products, if necessary to provide the highest levels of product quality.

## **Laminate:**

Each laminate shown in the REM swatch has been carefully selected from the Polyrey, Wilsonart & Egger Quality Collections of high pressure laminates (HPL). They can all be postformed (with the exception of Alu Brosse), and are suitable for commercial use. Please note that Matt Black has a tendency to fine scratching and finger marks when applied to horizontal working surfaces.

REM has made every effort to ensure that the Laminates presented in our swatch book are as the original. All products are subject to availability. REM reserves the right, without further notice, to alter the material specification of our products, if necessary to provide the highest levels of product quality.

Please ensure that you discuss any queries with our technical staff. For more colour ideas visit [www.rem.co.uk](http://www.rem.co.uk).

## **NOTE**

REM declines all responsibility for any injury to persons or damage to property caused by installation or assembly that has not been carried out in compliance with the general warnings, and the installation instructions of the pole/base and/or wall arm. REM declines all responsibility for any injury to persons or damage to property caused by installation or assembly carried out by non-qualified persons. REM declines all responsibility for injury or damage resulting from the unsuitability of the wall for the wall hood processor and arm only.

## **Environmental Protection**



The crossed-out wheeled bin symbol which you will find on the Rating Plate attached to your product, or appearing in the Assembly/Operating Instructions, signifies an obligation by you as purchaser or owner, to dispose of the equipment in accordance with the European Directive 2002/96/EC. This is a statutory instrument commonly known as the 'WEEE Regulations', which effectively requires you to carry out disposals of all Electrical and Electronic Equipment separately from your usual waste facilities. Specialist waste controls, designated by the Government (or Local Authorities) are to be made available to prevent potentially harmful substances affecting the environment and causing a possible human/animal health risk.

More detailed information is available from your local Environmental Health Office, Local Authority Waste Disposal Service, or the sales point from which the product was originally purchased.

REM's Producer Registration Number is **WEE/BJ0066TW**



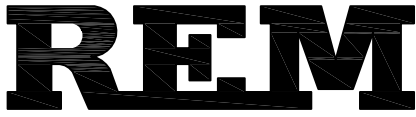

# Declaration

## Guarantee

### ***What this Warranty Covers***

This warranty covers any product defects arising from faulty materials or workmanship; or defects arising from direct delivery transport damage. It is important to note that damages must be reported within 72 hours and are only covered for the address on the REM delivery note. Any issues relating to incorrect specification or missing components must be reported within 28 days from delivery.

### ***What this Warranty Does Not Cover***

Any problems arising from damage caused by misuse, failure to install correctly, damage caused during 3rd party transportation and storage, or fair wear and tear. (Goods delivered by the wholesaler or courier arranged by the wholesaler or end user will be classed as 3rd party transportation.)

### ***What is the period of this Warranty?***

This Warranty extends for a period of three years from date of purchase. Customers must retain their receipt from the supplying REM Distributor as proof of purchase. Any wholesaler stock items will be covered for three years, where applicable, from date of purchase from the wholesaler but exclude transport damage.

### ***What we will do to correct problems***

REM will, at its discretion, repair or replace defective products. During the first year of ownership for UK Mainland customers only, REM will supply and, at its discretions, fit replacement parts or products. In years 2 and 3 for UK Mainland customers and for years 1, 2 and 3 for all customers outside UK Mainland, REM will supply replacement parts or products at its cost.

### ***What we will not do***

REM will not be responsible for any associated costs of refitting or reinstalling any products which have been replaced nor will it be responsible for any costs incurred arising from the non-availability of its products awaiting repair or replacement.

### ***How do you get service?***

Should any problems arise with your REM product please use the REM Support Link which is found at <http://www.remsupport.co.uk/>.

### ***How does this affect my statutory rights?***

This three year warranty in no way affects your statutory rights and is intended as an additional safeguard and benefit for buying and using REM products.

### ***Notable Exceptions to the warranty***

1. Miranda Dryer is covered by 12 month warranty only.
2. Rio Mag Lamp is covered by 12 month warranty only.
3. Apollo, Apollo Lux, Studio, Jupiter, Nero, Penta and Monet Trolleys are covered by 12 month warranty only.
4. Any repairs carried out by REM personnel or accredited REM engineers have a 3 month guarantee.

### ***Other Exceptions to the warranty***

1. Upholstered seats are covered by a 3 year warranty except for where cloth gathers or stretches under use.
2. Dryer Pole Wing Nuts are considered a wearable part and not covered by warranty.
3. Hoses for REM washpoints are considered a wearable part and not covered by warranty.
4. Handsets for REM electric couches are only covered by warranty for the first 12 months.
5. Stained Upholstery due to hair dye and other products are not covered by warranty.
6. Stained Upholstery due to denim or similar are not covered by warranty.
7. Stained work surfaces due to nail varnish and similar products are not covered by warranty.
8. Damaged glass components or mirrors are not covered under warranty unless the damage was occurred during delivery and reported within 72 hours.
9. Visors on REM Hood Dryer are covered by warranty for transit damage only.
10. Any items damaged in transit are only covered by warranty if delivered on REM vehicles or REM appointed subcontractors. Any items collected from REM by customers or where collection has been arranged by customers are not covered for any transit damage.
11. Any items purchased from REM Reconditioned stock, invoiced on a code beginning with 3045 are not covered by warranty.
12. Any items purchased from Ebay or similar are not covered by warranty.

### **REM Returns Policy**

All defects arising from faulty materials or poor workmanship; or defects arising from transport damage will be returned to REM at no cost to the customer.

Where REM agree to replace a product, the replacement item will be charged to the customer's account. The returned unit will be credited in full once it has been received back at REM. In cases where the reported fault cannot be found, no credit will be authorised.

Unwanted goods, or items not meeting customer requirements; which are free from the defects listed above, un-used, and in its original packaging will be considered for credit by a duly appointed representative of REM. A minimum charge of £60 will apply and will be communicated before the returns order is processed.

Items manufactured to the specific requirements of the customer (such as made-to-order furniture and upholstery; and bespoke furniture) are non-returnable. If the item is faulty it will be replaced or repaired at REM's cost, as per our terms and conditions.

REM will attempt collection of an arranged return a maximum of two times at which point the customer/wholesaler will have to arrange their own transportation for the goods to be sent back to REM or the returns note will be cancelled and any charges on the note will be applied to the account.

**Please ensure that you discuss any queries with our technical staff:**

**www.rem.co.uk**

**sales@rem.co.uk**

**customerservice@rem.co.uk**

**+44(0) 1282 619 917**

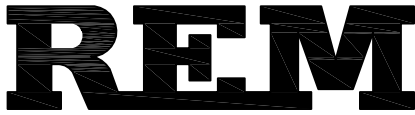

# Declaration

## Product Registration

In order to validate your warranty REM request that you register each of your products with our service department. Please email [customerservice@rem.co.uk](mailto:customerservice@rem.co.uk) and provide:

- Name
- Business Address
- Town/City
- Post Code
- Serial Number
- Date of Purchase

This information will be sent to your closest Service Engineer.

REGION	COMPANY	CONTACT	EMAIL ADDRESS	PHONE	MOBILE
NATIONAL	SALON CARE	MATT	<a href="mailto:SALONCAREUK@GMAIL.COM">SALONCAREUK@GMAIL.COM</a>	01256 353524	
KENT	WHY NOT FIX	ANDY DAVIES	<a href="mailto:ANDY@WHYNOTFIX.CO.UK">ANDY@WHYNOTFIX.CO.UK</a>	01303 891909	07861 707870
HAMPSHIRE	PROFESSIONAL HAIRDRYER SERVICES	COLIN HULME	<a href="mailto:COLIN.HULME@SKY.COM">COLIN.HULME@SKY.COM</a>	02380 778093	07795 432101
HAMPSHIRE/ WILTSHIRE		STUART PAYNE	<a href="mailto:STUART369PAYNE@BTINTERNET.COM">STUART369PAYNE@BTINTERNET.COM</a>	02380 420445	07957 649225
DORSET	MIKE DAVIES	SEIVAD SERVICES	<a href="mailto:MIKE@SEIVADSERVE.PLUS.COM">MIKE@SEIVADSERVE.PLUS.COM</a>	01202 889366	07984 456927
LONDON	VANGUARD	PAUL	<a href="mailto:SALES@VANGUARDHAIRDRYERS.CO.UK">SALES@VANGUARDHAIRDRYERS.CO.UK</a>	0208 6604437	07899 991889
EAST ANGLIA	HUMPHREY MOBILE SERVICES	DAVE/WILL	<a href="mailto:HUMPHREYMOBILE@SKY.COM">HUMPHREYMOBILE@SKY.COM</a>	01502 580609	07905 941704
WEST MIDLANDS, DERBYSHIRE, SHROPSHIRE, HEREFORD	MIDLAND DRYER SERVICES	DAVID KEMPER	<a href="mailto:DAVID.KEMPER@NTLWORLD.COM">DAVID.KEMPER@NTLWORLD.COM</a>	01889 570369	07977 861001
DERYSHIRE, STAFFS, NOTTS, LEICESTER	MULTICARE	MALCOLM	<a href="mailto:INFO@MULTICAREPROFESSIONAL.COM">INFO@MULTICAREPROFESSIONAL.COM</a>	01663 734151	07915 075544
SOUTH AND CENTRAL WALES	LEWIS SALON SERVICES	IAN LEWIS	<a href="mailto:IANIPS@MSN.COM">IANIPS@MSN.COM</a>	01267 238862	07974 072064
CHESHIRE, MERSEYSIDE, NORTH WALES	HAIRDRESSING EQUIPMENT SERVICES	TERRY PARKES	<a href="mailto:TERRYPARKES@GMAIL.COM">TERRYPARKES@GMAIL.COM</a>	01829 260164	07515 696010
LANCASHIRE	GORDEN FISHER	JULIE FISHER	<a href="mailto:JULIEFISHER19@ME.COM">JULIEFISHER19@ME.COM</a>	01253 738663	07721 436880
CUMBRIA	GORDON SINGLETON	GORDON SINGLETON	<a href="mailto:PB4@LIVE.CO.UK">PB4@LIVE.CO.UK</a>	01229 834068	07887 377629
YORKSHIRE	SELBY SALON SERVICES	DAVID JOHN	<a href="mailto:dgi9591@gmail.com">dgi9591@gmail.com</a>	01757 704477	07885 652840
YORKSHIRE	HAIRDRESSING ELECTRICAL EQUIPMENT	MICK BRADY		01132 120811	07767 676267
NORTH EAST	SAFETY 1 <sup>ST</sup>	ANDY KELLY	<a href="mailto:ANDYKELLY65@HOTMAIL.COM">ANDYKELLY65@HOTMAIL.COM</a>	01724 846573	07981 252739
SCOTLAND	RAZORSHARP	RAY SMITH	<a href="mailto:NIKERA@VIRGINMEDIA.COM">NIKERA@VIRGINMEDIA.COM</a>	01292 289206	07808 870358
NORTHERN IRELAND	SALON SUPPORT	IAN MACDONALD	<a href="mailto:IMACD66@HOTMAIL.COM">IMACD66@HOTMAIL.COM</a>	02891 820617	07803 158994
SOUTHERN IRELAND	HAIRDRESSING TRADE	MARK PEYTON	<a href="mailto:HAIRDRESSINGTRADE@GMAIL.COM">HAIRDRESSINGTRADE@GMAIL.COM</a>	00353 872 624419	
SOUTH IRELAND		JOHN – CO CORK		00353 872 398932	