

Product Codes:

- 01590 - Dream Pedispa

Standard Equipment:

- Manually adjustable footrest
- Retractable tap (WRAS approved)
- Whirl pool motor
- Porcelain basin
- Laminated basin cover

Optional Equipment:

- N/A

Main Construction:

- Interior plywood construction with foam toppers.
- Any REM laminate to base
- Any REM fabric to seat
- Ceramic basin

Finish:

- Any fabric & laminate from the REM range. All REM fabrics are fire retardant to Crib 5.

Features:

- Unique Design
- Choice of any REM colours with feature buttoning on seat
- Adjustable footrest
- Retractable tap
- Laminated basin cover

Plumbing Details:

Included:

- Hot & cold flexi pipe
- to fit 15mm copper pipe
- Pop Up Waste
- 1 ¼ (32mm)

Optional Extra:

- Bottle Trap A10A
- 1 ¼ (32mm)

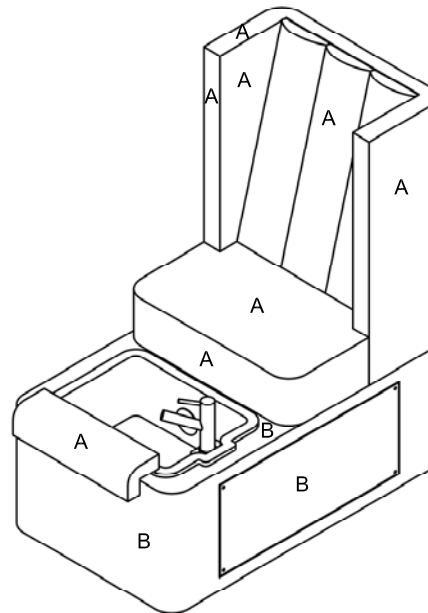
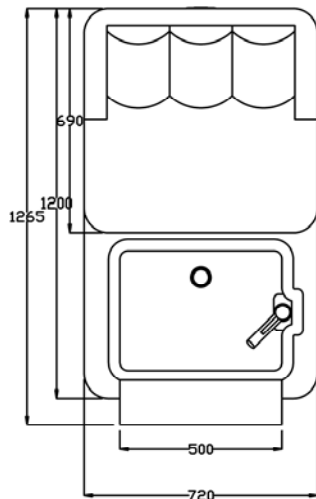

A = Fabric
B = Laminate

Unit Options:

- 03954 Embroidery Small
- 03955 Embroidery Large (embroidery to rear of chairs)

Optional extras must be clearly detailed at time of order.

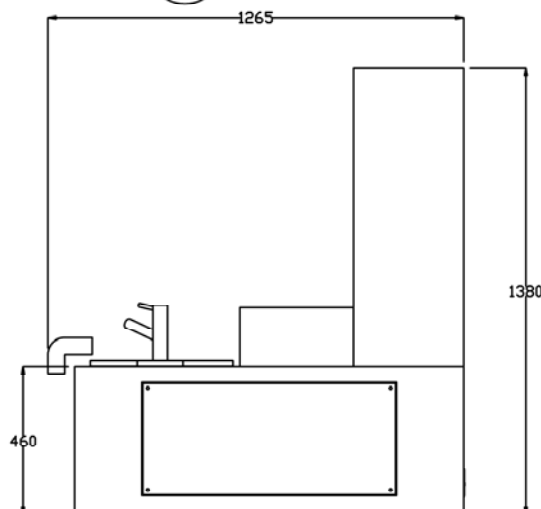
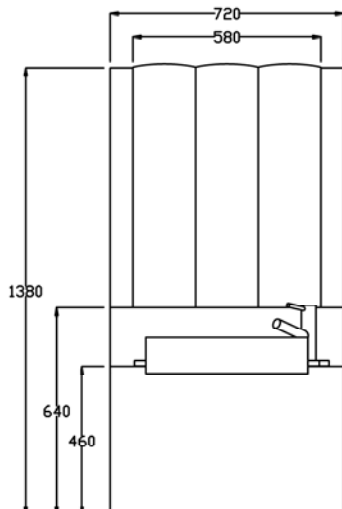

*NOTE: sizes may vary slightly from shown

REM declines all responsibility for any injury to persons or damage to property caused by faulty installation or assembly carried out by non-qualified persons.
 NOTE: These are recommended fitting instructions. Please discuss our recommendations with a qualified furniture fitter.

Note: additional plumbing components may be required but are not supplied by REM, they can be purchased from local plumbing shops

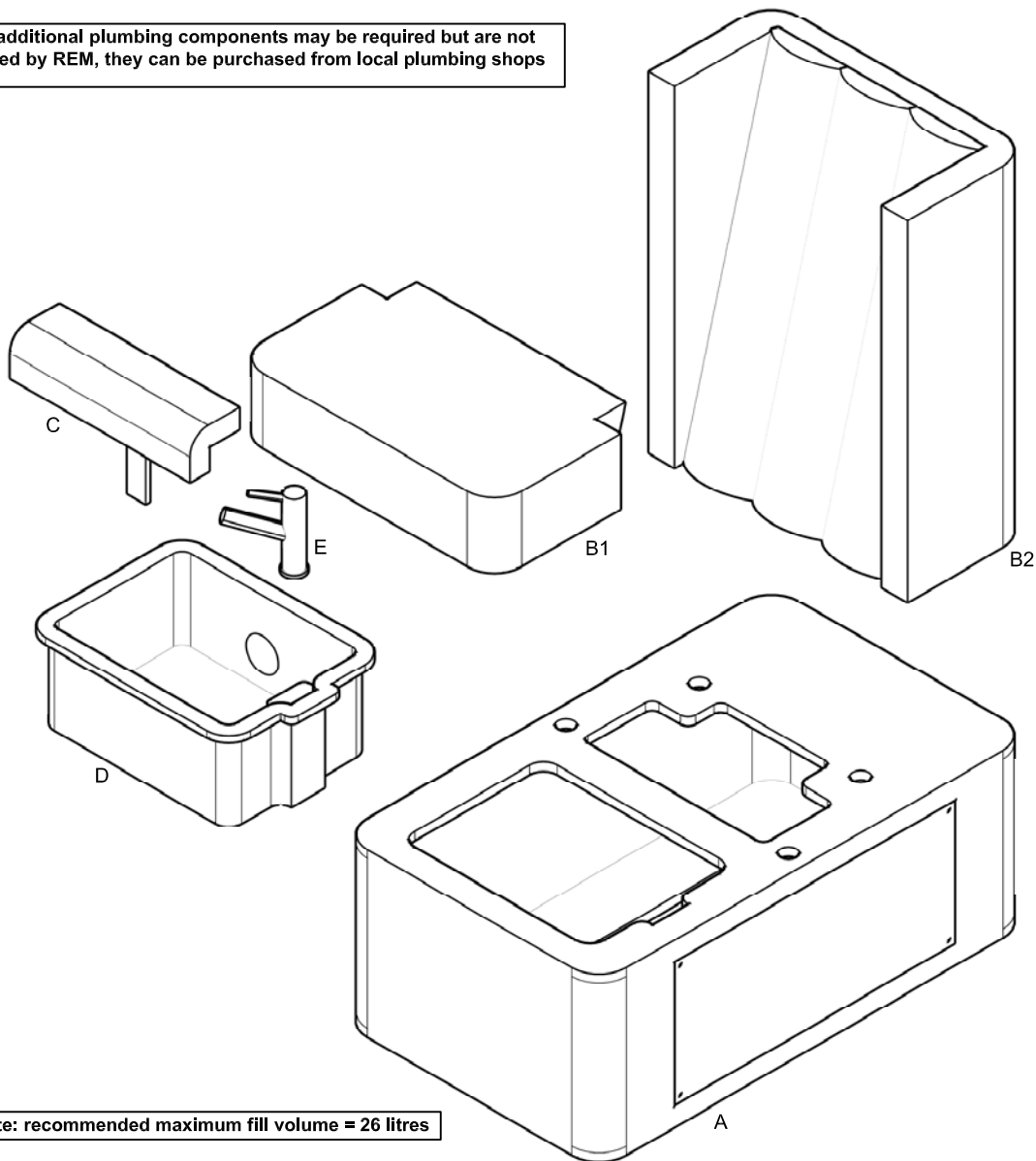

- A : Dream Pedispa Unit
- B1 : Seat Section
- B2 : Back Section
- C : Footrest Section
- D : Basin
- E : Tap & Waste Kit

NOT SHOWN:
 F : M8 Bolts x 10

Note: recommended maximum fill volume = 26 litres

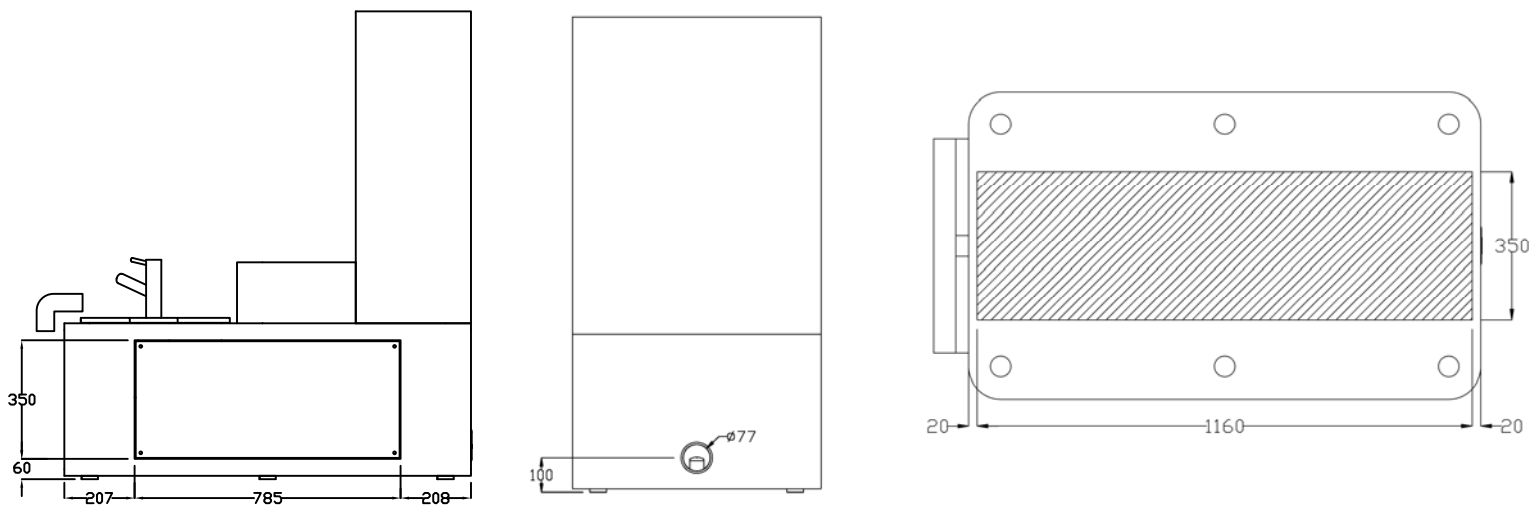

Side Access Points - Unfasten 4 x fixings to gain access to side panel, remove port hole for any rear pipe access.

Base plumbing access position to suit onsite requirements

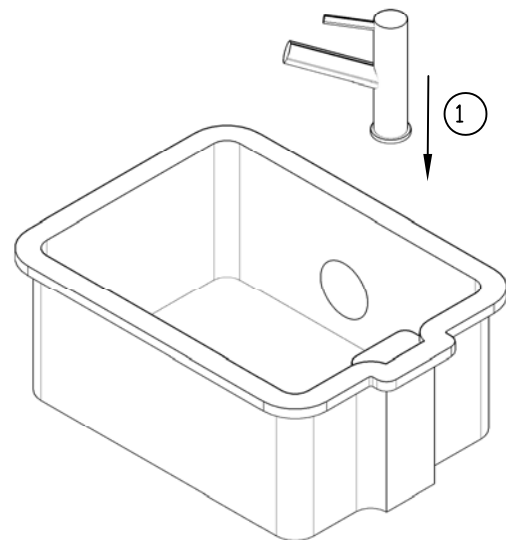
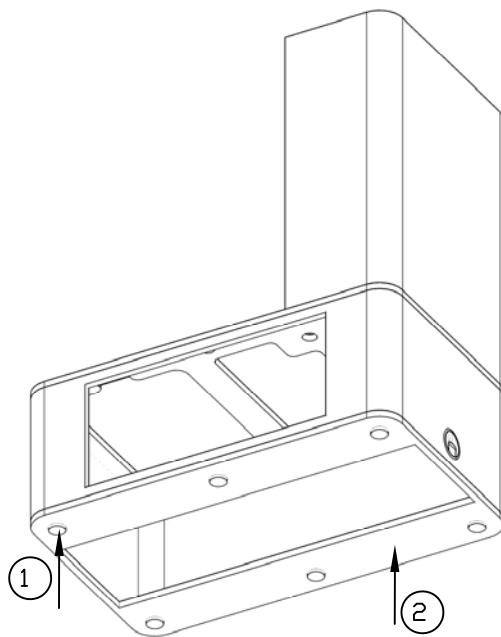
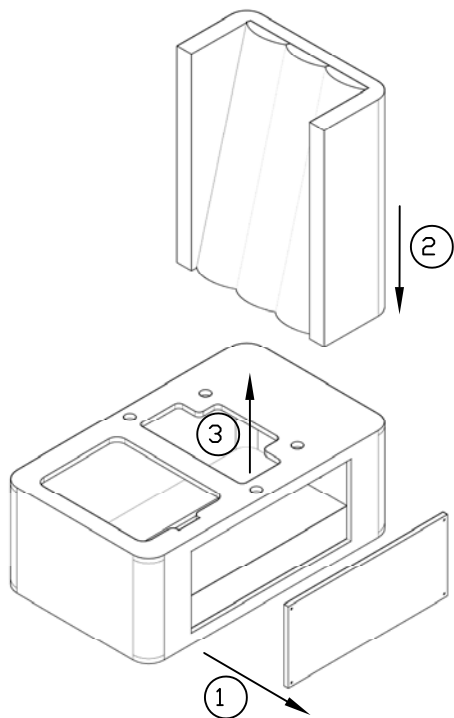

1. Carefully unwrap components and ensure all pieces are in order.
Remove side access panel in order to install and plumb unit [1].
Remove footrest section (C) and lift off seat section (B1) for easy access during installation.
2 person stage:
Carefully place Back Section (B2) onto Unit (A)[2], fix into position from underside of unit using M8 Bolts (F) provided [3].

3. Place Dream Pedispa Unit (A) into position. Adjust feet to underside and ensure unit surface is horizontal [1].
Unit can be fastened into position to avoid movement, no floor fixings provided [2].

4. Install Tap & Waste kit (E) to Basin (D) - see separate instructions with tap kit [1].

IMPORTANT NOTICE

Salon owners should be advised to engage the services of a qualified plumber when installing basins / taps, and completing any plumbing work.

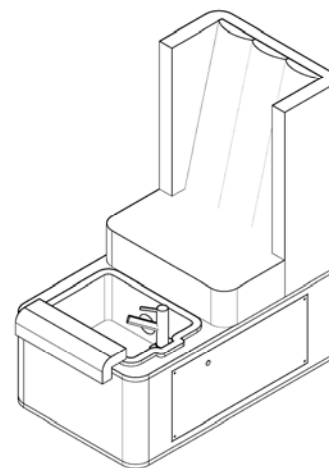
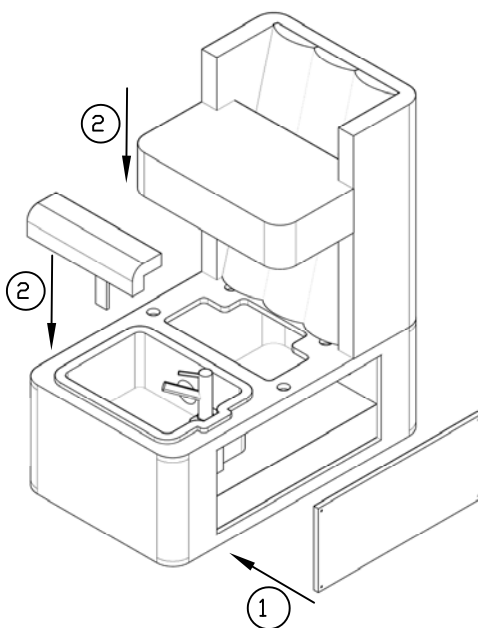
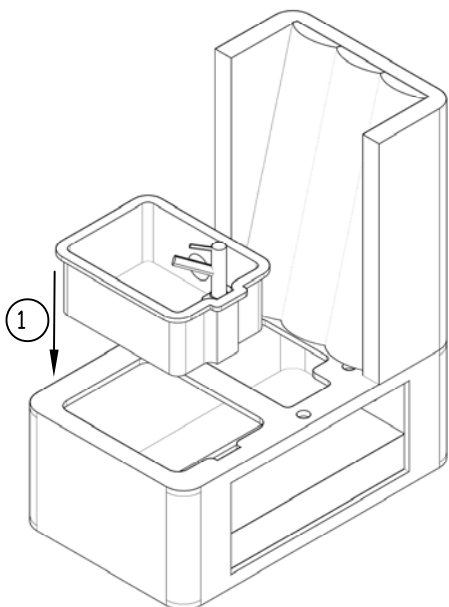

5. Carefully lower Basin (D) into position [1]
The basin must be bedded on Silicone Sealant (not provided), and fully sealed before use.

6. Connect unit to on-site power supply. Replace side access panel [1].
Replace footrest section (C) and seat section (B1) [2].

Complete plumbing work required, connecting to onsite water and waste feeds.

Unit complete
NOTE: CENTENARY PEDISPA IS SUPPLIED WITH 2m LONG CABLE TO BE SAFELY CONNECTED TO ON-SITE POWER SUPPLY (NO PLUG INCLUDED)

The Dream Pedispa is supplied with Whirlpool feature. This unit must be installed, inspected, and tested by qualified personnel to meet the Requirements for Electrical Installations, IEE Wiring Regulations, 17th Edition. Advice on further periodic inspection and testing should be sought from the technician carrying out the initial installation. Once installed, movement of the unit, modifications, repairs etc. should only be carried out in accordance with the contents of this notice.

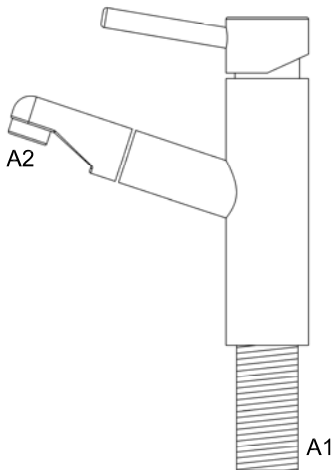

A package of component parts may be found to contain:

- A1 Mixer Valve
- A2 Hand-Spray
- B Chrome Collar
- C Black Rubber Washer
- D Metal Washer
- E Brass Lock Nut
- F Cold Feed
- G Hot Feed
- H Hand Spray Feed
- I Hand Spray Flexi Pipe
- J Black Rubber Washer

Not Shown:

- K Cold Flexi Pipe
- L Hot Flexi Pipe
- M Hand Spray Weight Ballast

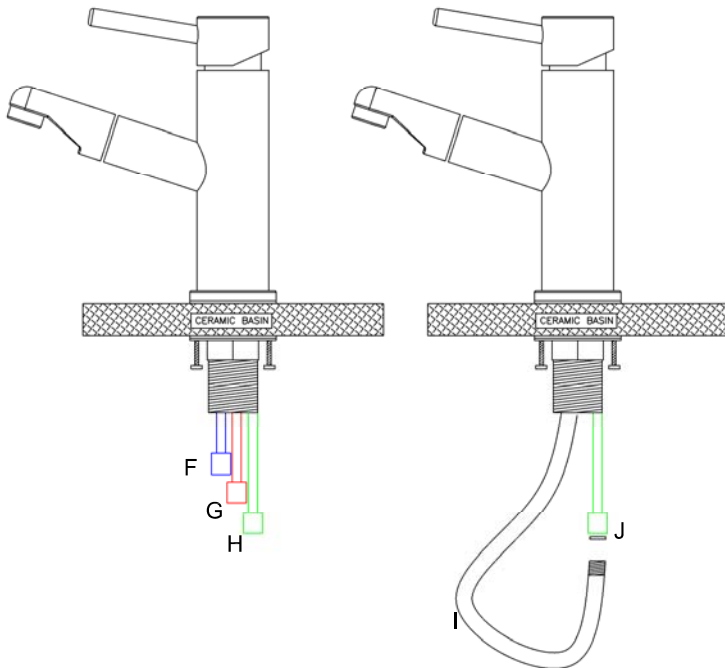
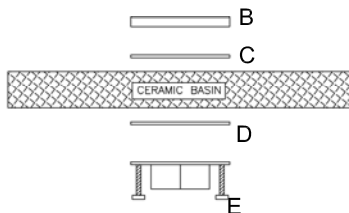

IMPORTANT NOTICE

Salon owners should be advised to engage the services of a qualified plumber when installing taps / basins, not least, to ensure that there is adequate mains water pressure available, particularly where 2 or more units are in operation.

Occasionally, in low water pressure areas, a pump may be required. As a guide the water pressure should be between 1.75 - 2.5 BAR equal pressure per outlet.

1. Carefully secure tap to basin, the thread on Mixer Valve (A) should lower between the Chrome Collar (B) and Black Rubber Washer (C) before the basin.
2. From below, slide Metal Washer & Brass Lock Nut (D&E) over Mixer valve thread and secure in position - DO NOT OVER TIGHTEN. (recommend fitting tap at 45 degree angle)
3. Attach Cold & Hot Flexi Pipes (K&L) to Cold & Hot Feeds (F&G)
4. Attach Hand Spray Flexi Pipe (I) with Black Rubber Washer (J) to Hand Spray Feed (H)
5. Connect Hot & Cold feeds, and basin waste pipe to on-site plumbing facilities
6. Secure Hand Spray Weight Ballast (M) inside unit around Hand Spray Flexi Pipe (I) - this helps Flexi Pipe travel back into the unit when in use.

OTHER NOTES

- Ensure adequate Hot & Cold balanced supply to meet requirements of all units being fitted. Minimum 2.5 Bar per outlet Pump(s) may be required in Low Pressure Areas.
- Please ensure that the hose and handspray are tightened mechanically, by the use of plumbers grip or similar. REM recommend the use of a sealant tape (such as PTFE tape) between the two components
- Avoid use of detergents when cleaning leathercloths. (Soap and water should be adequate).
- REM guarantee all Units against manufacturing fault only, for a period of twelve months.

The terms of this guarantee do not affect your Statutory Rights.

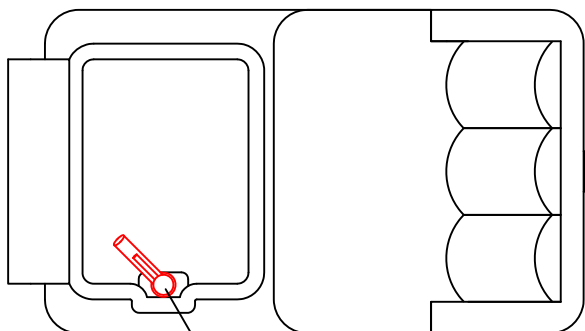

Recommended fitting of tap at 45 degree angle to allow added space for client

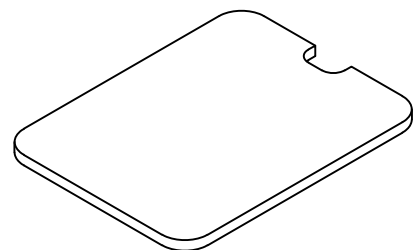

Basin Cover

WARNING: do not stand on the basin cover due to risk of damage or injury.

Basin cover must be kept clean and dry at all times.

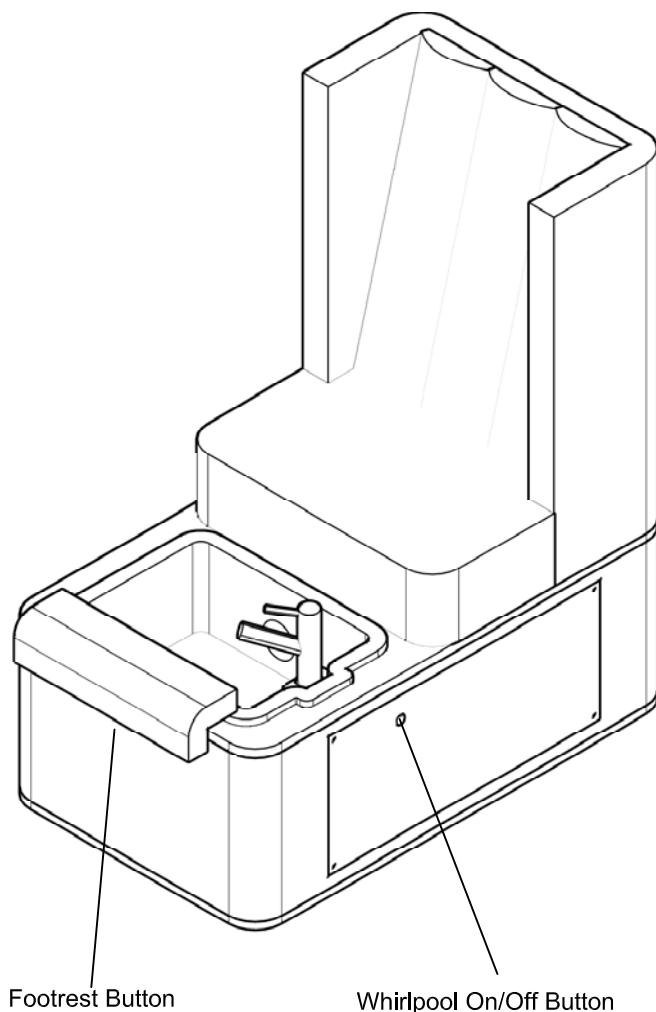

Whirl Pool Motor

Power on/off button is located on side of unit. The button will illuminate when in use and flash during 'cool down' period.

When turned on the whirlpool motor will operate for a maximum of 10 minutes and turn off automatically. During 'cool down' period the motor cannot be restarted for 5 minutes until the power button light stops flashing.

MAXIMUM OPERATING TIME: 10 minutes

MAXIMUM COOL DOWN TIME: 5 minutes

Cool down ratio is 30 seconds cool down for every 60 seconds operating time up to a maximum operating time of 10 minutes.

NOTICE: DISCONNECTING POWER WILL NOT RESET COOL DOWN OPERATION.

WARNING: ALWAYS ENSURE WHIRL POOL MOTOR IS FULLY COVERED BY WATER BEFORE OPERATING.

Mixer Tap

Tap is operated by lifting handle and turning to reach required temperature. The tap head is extractable and can be lifted from the main tap body - replace when not in use.

Care should be taken to avoid excess water exiting the basin area.

DO NOT GAIN ACCESS TO, TAMPER WITH OR MODIFY ANY OF THE ELECTRICAL COMPONENTS ON THIS UNIT - USE A QUALIFIED TECHNICIAN ONLY.

Fabrics:
DECLARATION OF CONFORMITY OF CERTAIN FIRE RETARDANCY STANDARDS.

BS 7176 is the British Standard which specifies the requirements for the resistance to ignition of upholstered furniture manufactured for seating or similar usage, but excluding use on domestic furniture or transport seating. Tests have been carried out on all REM products and fabrics in accordance with BS EN 1021-1: 2006 and BS EN 1021-2: 2006 which satisfy the performance requirements of Low Hazard Category of BS 7176 (resistance to ignition sources: Smouldering Cigarette and Match Flame Equivalent).

Typical examples of furniture that are required to meet the Low Hazard Category are Schools, Colleges, Offices, and Day Centres.

All of the cloths the REM swatch are available on the majority of REM products and meet the Medium Hazard Category (Public Buildings, Restaurants, Hotel Bedrooms, Hospitals etc) of BS 7176 which is similar to the above but also includes the Ignition Source 5 test of BS 5852: 2006.

It should be noted also, that whilst the test levels for the various hazard categories are set after careful consideration of the particular end-user environments involved, they are not intended to reflect the behaviour of the upholstery in a fully developed fire. A label is available for use on items produced in accordance with this standard, although there is no legal requirement to attach said label. These can be supplied on request at the time of ordering (printed to suit Low and Medium Hazard Only).

All products are subject to availability. REM reserves the right, without further notice, to alter the material specification of our products, if necessary to provide the highest levels of product quality.

Laminate:
Each laminate shown in the REM swatch has been carefully selected from the Polyrey, Wilsonart & Egger Quality Collections of high pressure laminates (HPL). They can all be postformed (with the exception of Alu Brosse), and are suitable for commercial use. Please note that Matt Black has a tendency to fine scratching and finger marks when applied to horizontal working surfaces.

REM has made every effort to ensure that the Laminates presented in our swatch book are as the original. All products are subject to availability. REM reserves the right, without further notice, to alter the material specification of our products, if necessary to provide the highest levels of product quality.

Please ensure that you discuss any queries with our technical staff. For more colour ideas visit www.rem.co.uk.

NOTE
REM declines all responsibility for any injury to persons or damage to property caused by installation or assembly that has not been carried out in compliance with the general warnings, and the installation instructions of the pole/base and/or wall arm. REM declines all responsibility for any injury to persons or damage to property caused by installation or assembly carried out by non-qualified persons. REM declines all responsibility for injury or damage resulting from the unsuitability of the wall for the wall hood processor and arm only.

Environmental Protection



The crossed-out wheeled bin symbol which you will find on the Rating Plate attached to your product, or appearing in the Assembly / Operating Instructions, signifies an obligation by you as purchaser or owner, to dispose of the equipment in accordance with the European Directive 2002/96/EC. This is a statutory instrument commonly known as the 'WEEE Regulations', which effectively requires you to carry out disposals of all Electrical and Electronic Equipment separately from your usual waste facilities. Specialist waste controls, designated by the Government (or Local Authorities) are to be made available to prevent potentially harmful substances affecting the environment and causing a possible human/animal health risk.

More detailed information is available from your local Environmental Health Office, Local Authority Waste Disposal Service, or the sales point from which the product was originally purchased.

REM's Producer Registration Number is **WEE/BJ0066TW**

Manufacturer: REM (UK) Limited

EU Authorised Representative: Comply Express Unipessoal Limitada, StartUp Madeira, EV141, Campus da Penteada, 9020 105 Funchal, Portugal

Guarantee

What this Warranty Covers

This warranty covers any product defects arising from faulty materials or workmanship; or defects arising from direct delivery transport damage. It is important to note that damages must be reported within 72 hours and are only covered for the address on the REM delivery note. Any issues relating to incorrect specification or missing components must be reported within 28 days from delivery.

What this Warranty Does Not Cover

Any problems arising from damage caused by misuse, failure to install correctly, damage caused during 3rd party transportation and storage, or fair wear and tear. (Goods delivered by the wholesaler or courier arranged by the wholesaler or end user will be classed as 3rd party transportation.)

What is the period of this Warranty?

This Warranty extends for a period of three years from date of purchase. Customers must retain their receipt from the supplying REM Distributor as proof of purchase. Any wholesaler stock items will be covered for three years, where applicable, from date of purchase from the wholesaler but exclude transport damage.

What we will do to correct problems

REM will, at its discretion, repair or replace defective products. During the first year of ownership for UK Mainland customers only, REM will supply and, at its discretion, fit replacement parts or products. In years 2 and 3 for UK Mainland customers and for years 1, 2 and 3 for all customers outside UK Mainland, REM will supply replacement parts or products at its cost.

What we will not do

REM will not be responsible for any associated costs of refitting or reinstalling any products which have been replaced nor will it be responsible for any costs incurred arising from the non-availability of its products awaiting repair or replacement.

How do you get service?

Should any problems arise with your REM product please use the REM Support Link which is found at <http://www.remsupport.co.uk/>.

How does this affect my statutory rights?

This three year warranty in no way affects your statutory rights and is intended as an additional safeguard and benefit for buying and using REM products.

Notable Exceptions to the warranty

1. Apollo, Apollo Lux, Blush and Studio Trolleys are covered by 12 month warranty only.
2. Any repairs carried out by REM personnel or accredited REM engineers have a 3 month guarantee.

Other Exceptions to the warranty

1. Upholstered seats are covered by a 3 year warranty except for where cloth gathers or stretches under use.
2. Dryer Pole Wing Nuts are considered a wearable part and not covered by warranty.
3. Hoses for REM washpoints are considered a wearable part and not covered by warranty.
4. Handsets for REM electric couches are only covered by warranty for the first 12 months.
5. Stained Upholstery due to hair dye and other products are not covered by warranty.
6. Stained Upholstery due to denim or similar are not covered by warranty.
7. Stained work surfaces due to nail varnish and similar products are not covered by warranty.
8. Damaged glass components or mirrors are not covered under warranty unless the damage occurred during delivery and reported within 72 hours.
9. Ceramic / Steel Basins are not covered for any cosmetic damage or any marks caused by equipment / jewellery / misuse.
10. Visors on REM Hood Dryer are covered by warranty for transit damage only.
11. Any items damaged in transit are only covered by warranty if delivered on REM vehicles or REM appointed subcontractors. Any items collected from REM by customers or where collection has been arranged by customers are not covered for any transit damage.
12. Any items purchased from REM Reconditioned stock, invoiced on a code beginning with 3045 are not covered by warranty.
13. Any items purchased from Ebay or similar are not covered by warranty.

REM Returns Policy

- All defects arising from faulty materials or poor workmanship; or defects arising from transport damage will be returned to REM at no cost to the customer.
- Where REM agree to replace a product, the replacement item will be charged to the customer's account. The returned unit will be credited in full once it has been received back at REM. In cases where the reported fault cannot be found, no credit will be authorised.
- Unwanted goods, or items not meeting customer requirements; which are free from the defects listed above, un-used, and in its original packaging will be considered for credit by a duly appointed representative of REM. A minimum charge of £60 will apply and will be communicated before the returns order is processed.
- Items manufactured to the specific requirements of the customer (such as made-to-order furniture and upholstery; and bespoke furniture) are non-returnable. If the item is faulty it will be replaced or repaired at REM's cost, as per our terms and conditions.
- REM will attempt collection of an arranged return a maximum of two times at which point the customer/wholesaler will have to arrange their own transportation for the goods to be sent back to REM or the returns note will be cancelled and any charges on the note will be applied to the account.

Please ensure that you discuss any queries with our technical staff:

www.rem.co.uk sales@rem.co.uk customerservice@rem.co.uk +44(0) 1282 619 917 ©REM UK Limited